

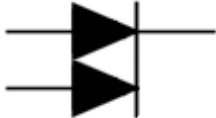

PHASE CONTROL DIODE MODULES

MDDC-160

<ul style="list-style-type: none"> ◆ $V_{RRM} = \underline{400\text{ V-1600 V}}$ ◆ $I_{F(AV)} = \underline{160\text{ A}}$ ($T_C = 89\text{ °C}$) ◆ $I_{FSM} = \underline{6\text{ kA}}$ ($T_j = 125\text{ °C}$) 		
<ul style="list-style-type: none"> ◆ Presspack construction ◆ Heat transfer through AlN ceramic isolated metal baseplate ◆ High reliability at thermal cycles (10^5 at $\Delta T_C = 70\text{ °C}$) ◆ Case width 34 mm 		

MAXIMUM RATED VALUES

Parameter and conditions	Symbol	Values	Units
Repetitive peak reverse voltage, $T_j = -40 \dots +125\text{ °C}$	V_{RRM}	400-1600	V
Non- repetitive peak reverse voltage, $T_j = -40 \dots +125\text{ °C}$	V_{RSM}	500-1700	
Repetitive peak reverse current, $T_j = 125\text{ °C}$, $V_R = V_{RRM}$	I_{RRM}	30	mA
Maximum average on-state current, $f = 50\text{ Hz}$, $T_C = 89\text{ °C}$	$I_{F(AV)}$	160	A
RMS on-state current, $T_C = 89\text{ °C}$	I_{FRMS}	251	
Surge non-repetitive current, $T_j = 125\text{ °C}$, $t_p = 10\text{ ms}$, $V_R = 0$	I_{FSM}	6	kA
Safety factor	I^2t	$0,180 \cdot 10^6$	A^2s
Operation junction temperature range	T_j	-40 ... +125	°C
Storage temperature range	T_{stg}	-40 ... +50	



MDDC-160

ELECTRICAL CHARACTERISTICS					
Parameter and conditions	Symbol	Values			Units
		min	type	max	
Maximum peak forward voltage, $T_j = 25\text{ °C}, I_F = 500\text{ A}$,	V_{FM}	-	-	1,25	V
On-state threshold voltage, $T_j = 125\text{ °C}, I_F = 250 - 700\text{ A}$	$V_{F(TO)}$	-	-	0,90	
On-state slope resistance, $T_j = 125\text{ °C}, I_F = 250 - 700\text{ A}$	r_T	-	-	0,55	mΩ
Electrical isolated baseplate (RMS), $f = 50\text{ Hz}, t = 1\text{ sec}/1\text{min}$	V_{isol}	-	-	3000/2500	V
THERMAL PARAMETERS					
Thermal resistance junction to case	$R_{th(j-c)}$	-	-	0,180	°C/W
Thermal resistance case to heatsink	$R_{th(c-h)}$	-	-	0,010	
MECHANICAL PARAMETERS					
Weight	w	-	0,45	-	kg
Heatsink mounting torque	M_s	4	-	6	Nm
Terminal connection torque	M_t	1,5	-	3,5	Nm
Maximum acceleration (at nominal mounting force)	a	-	-	50	m/s ²



MDDC-160

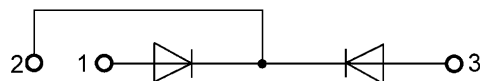
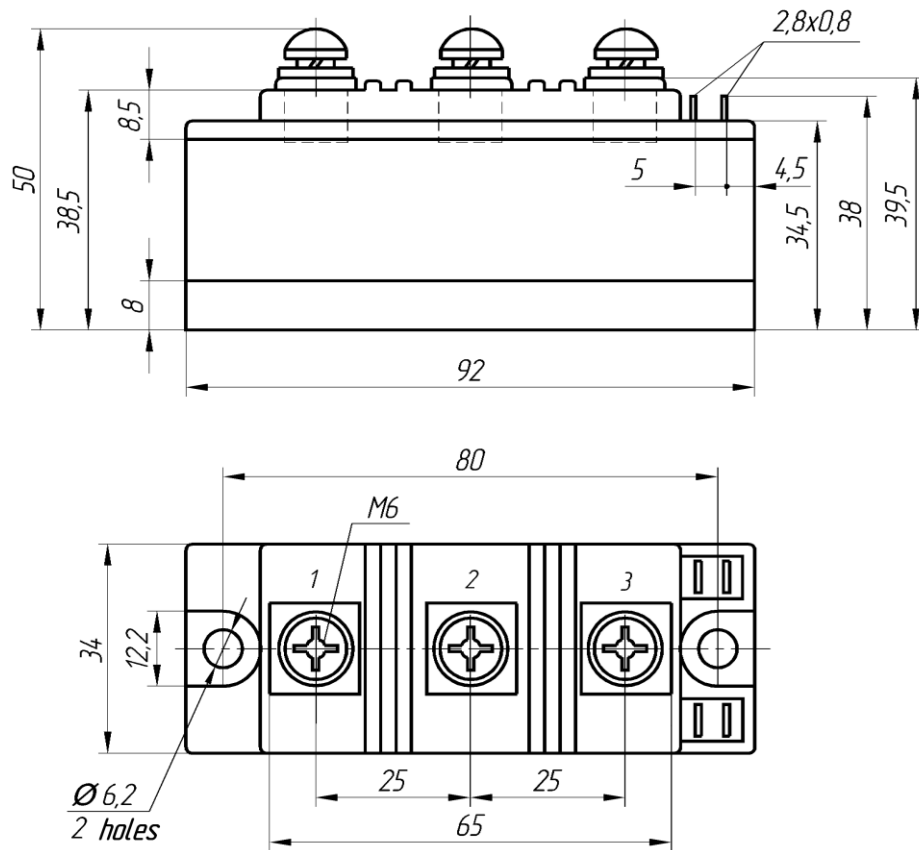

1, 3 – Anode; 2 – Cathode

Device Outline Drawing

(dimensions in mm)



126, Proletarskaya str.,

430001, Saransk, Republic Mordovia, Russia

Tel: +7(8342) 47-04-30

Tel/Fax: +7 (8342) 47-15-01

E-mail: vpruvs@elvpr.ru

Internet: www.elvpr.ru Internet: www.elvpr.ru