



## PHASE CONTROL THYRISTOR T193-5000

<ul style="list-style-type: none"> <li>◆ <math>V_{DRM} = 800 - 1800 \text{ V}</math></li> <li>◆ <math>V_{RRM} = 800 - 1800 \text{ V}</math></li> <li>◆ <math>I_{T(AV)} = 6250 \text{ A}</math> (<math>T_C = 70 \text{ }^\circ\text{C}</math>)</li> <li>◆ <math>I_{T(AV)} = 5015 \text{ A}</math> (<math>T_C = 85 \text{ }^\circ\text{C}</math>)</li> <li>◆ <math>I_{TSM} = 100 \text{ kA}</math> (<math>T_j = 125 \text{ }^\circ\text{C}</math>)</li> </ul>		
<ul style="list-style-type: none"> <li>◆ Amplifying gate</li> <li>◆ Low on-state switching losses</li> <li>◆ Acceptable for series and parallel connections</li> <li>◆ Low dispersion <math>Q_{rr}</math>, <math>V_{TM}</math></li> </ul>		

### MAXIMUM RATED VALUES

Parameter and conditions	Symbol	Values	Units
Repetitive peak off-state voltage, $T_j = -60 \dots +125 \text{ }^\circ\text{C}$	$V_{DRM}$	800 - 1800	V
Repetitive peak reverse voltage, $T_j = -60 \dots +125 \text{ }^\circ\text{C}$	$V_{RRM}$	800 - 1800	
Non-repetitive peak off-state voltage, $T_j = -60 \dots +125 \text{ }^\circ\text{C}$	$V_{DSM}$	900 - 1900	
Non-repetitive peak reverse voltage, $T_j = -60 \dots +125 \text{ }^\circ\text{C}$	$V_{RSM}$	900 - 1900	
Repetitive peak off-state current/ Repetitive peak reverse current, $T_j = 125 \text{ }^\circ\text{C}$ , $V_D / V_R = V_{DRM} / V_{RRM}$	$I_{DRM} / I_{RRM}$	200	mA
Average on-state current, $f = 50 \text{ Hz}$ , double side cooling, $T_C = 85 \text{ }^\circ\text{C}$ $T_C = 70 \text{ }^\circ\text{C}$	$I_{T(AV)}$	5015 6250	A
RMS on-state current, $T_C = 70 \text{ }^\circ\text{C}$ , $f = 50 \text{ Hz}$	$I_{TRMS}$	9817	A
Surge non-repetitive on-state current, $T_j = 125 \text{ }^\circ\text{C}$ , $V_R = 0$ , $t_p = 10 \text{ ms}$	$I_{TSM}$	100	kA
Safety factor	$I^2t$	$5 \cdot 10^7$	$A^2s$
Critical rate of rise of on-state current, $T_j = 125 \text{ }^\circ\text{C}$ , $V_D = 0.67V_{DRM}$ , $I_T = 10000 \text{ A}$ , $I_{FG} = 2 \text{ A}$ , $t_r = 1 \text{ } \mu\text{s}$ , $f = 50 \text{ Hz}$	$(di_T/dt)_{crit}$	200	$A/\mu\text{s}$
Critical rate of rise of off-state voltage, $T_j = 125 \text{ }^\circ\text{C}$ , $V_D = 0.67V_{DRM}$	$(dv_D/dt)_{crit}$	1000 - 1600	$V/\mu\text{s}$
Gate power loss, DC	$P_{GM}$	4	W
Operation junction temperature range	$T_j$	-60... +125	$^\circ\text{C}$
Storage temperature range	$T_{stg}$	-60... +50	



## T193-5000

ELECTRICAL CHARACTERISTICS					
Parameter and conditions	Symbol	Values			Units
		min	typ.	max	
Peak on-state voltage, $T_j = 25\text{ °C}$ , $I_T = 15708\text{ A}$	$V_{TM}$	-	-	1.48	V
On-state threshold voltage, $T_j = 125\text{ °C}$ , $I_T = 7850 - 23560\text{ A}$	$V_{T(TO)}$	-	-	0.83	
On-state slope resistance, $T_j = 125\text{ °C}$ , $I_T = 7850 - 23560\text{ A}$	$r_T$	-	-	0.048	mΩ
Delay time, $T_j = 25\text{ °C}$ , $V_D = 0.50V_{DRM}$ , $I_T = 5000\text{ A}$ , $I_{FG} = 2\text{ A}$ , $t_r = 0.5\text{ μs}$	$t_d$	-	-	3.5	μs
Turn off-time, $T_j = 125\text{ °C}$ , $I_T = 5000\text{ A}$ , $di_T/dt = -5\text{ A/μs}$ , $V_R \geq 100\text{ V}$ , $V_D = 0.67V_{DRM}$ , $dv_D/dt = 50\text{ V/μs}$	$t_q$	-	250	-	
Reverse recovery charge, $T_j = 125\text{ °C}$ , $I_T = 5000\text{ A}$ , $di_T/dt = -5\text{ A/μs}$ , $V_R \geq 100\text{ V}$	$Q_{RR}$	-	-	1500	μAs
Holding current, $T_j = 25\text{ °C}$ , $V_D = 12\text{ V}$	$I_H$	-	-	300	mA
Latching current, $T_j = 25\text{ °C}$ , $V_D = 12\text{ V}$ , $I_{FG} = 2\text{ A}$ , $t_r = 0.5\text{ μs}$	$I_L$	-	-	1500	
Gate trigger voltage, $V_D = 12\text{ V}$ , $T_j = -60\text{ °C}$ $T_j = 25\text{ °C}$ $T_j = 125\text{ °C}$	$V_{GT}$	-	-	3.5 2.5 2.0	V
Gate trigger current, $V_D = 12\text{ V}$ , $T_j = -60\text{ °C}$ $T_j = 25\text{ °C}$ $T_j = 125\text{ °C}$	$I_{GT}$	-	-	450 250 200	mA
Gate non-trigger direct voltage, $T_j = 125\text{ °C}$ , $V_D = 0.67V_{DRM}$	$V_{GD}$	0.25	-	-	V
Gate non-trigger direct current, $T_j = 125\text{ °C}$ , $V_D = 0.67V_{DRM}$	$I_{GD}$	15	-	-	mA
THERMAL PARAMETERS					
Thermal junction to case resistance, DC: double side cooled DC: anode side cooled DC: cathode side cooled	$R_{th(j-c)}$ $R_{th(j-cA)}$ $R_{th(j-cK)}$	-	-	0.0056 0.0112 0.0112	°C/W
Thermal case to heatsink resistance, double side cooled single side cooled	$R_{th(c-h)}$	-	-	0.003 0.006	
MECHANICAL PARAMETERS					
Weight	w	-	3.0	-	kg
Clamping force	F	80	-	100	kN
Maximum acceleration (at nominal mounting force)	a	-	-	100	m/s <sup>2</sup>
Minimal gate-anode distance on insulator surface	$D_s$	-	59	-	mm



## T193-5000

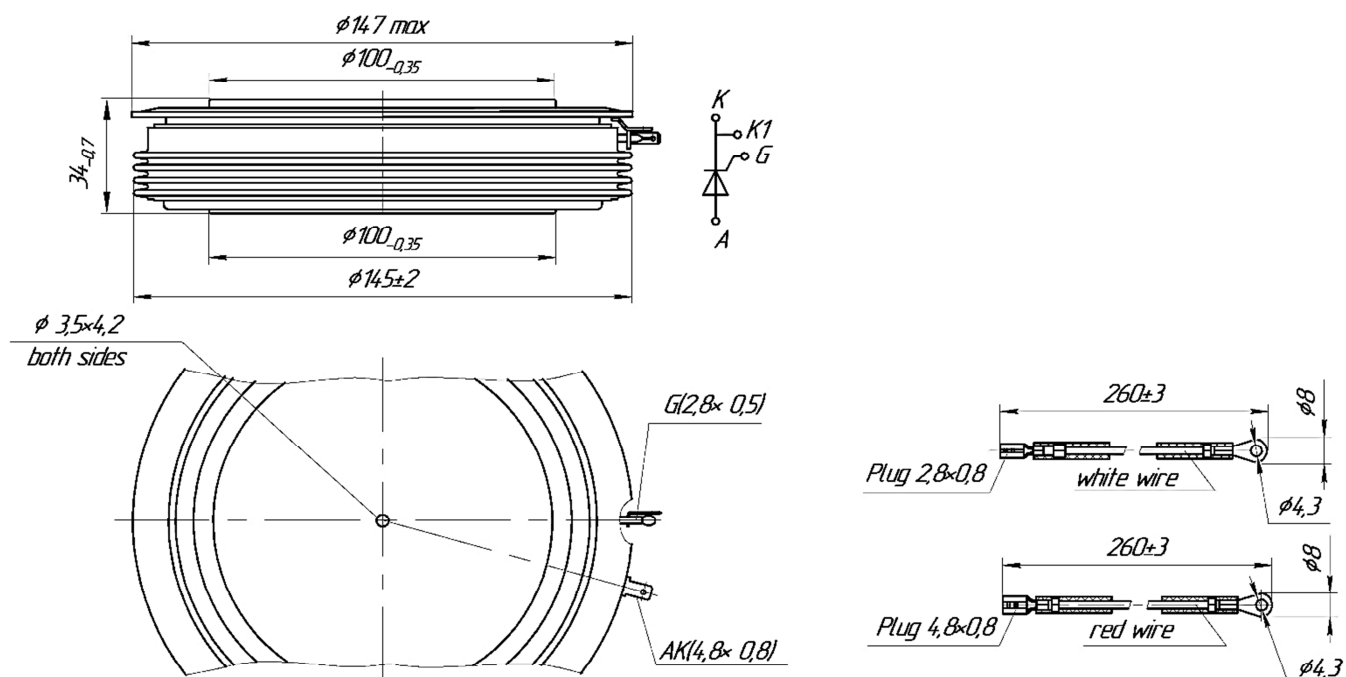

Device Outline Drawing  
(dimensions in mm)



126, Proletarskaya str.,  
430001, Saransk, Republic Mordovia, Russia  
Tel: +7(8342) 47-04-30  
Tel/Fax: +7 (8342) 47-15-01  
E-mail: vpruvs@elvpr.ru  
Internet: www.elvpr.ru