



PHASE CONTROL THYRISTOR

T161-200

<ul style="list-style-type: none"> ◆ $V_{DRM} = \underline{300-1600\text{ V}}$ ◆ $V_{RRM} = \underline{300-1600\text{ V}}$ ◆ $I_{T(AV)} = \underline{200\text{ A}}$ ($T_C = 87\text{ °C}$) ◆ $I_{TSM} = \underline{5\text{ kA}}$ ($T_j = 125\text{ °C}$) 		
<ul style="list-style-type: none"> ◆ Hermetic metal cases with ceramic ◆ Pressure contact design ◆ Threaded studs of ISO 		

MAXIMUM RATED VALUES

Parameter and conditions	Symbol	Values	Units
Repetitive peak off-state voltage / Repetitive peak reverse voltage, $T_j = -60\text{ °C} \dots +125\text{ °C}$	V_{DRM} / V_{RRM}	300-1600	V
Non-repetitive peak off-state voltage/Non- repetitive peak reverse voltage, $T_j = -60\text{ °C} \dots +125\text{ °C}$	V_{DSM} / V_{RSM}	400-1700	
Repetitive peak off-state current/ Repetitive peak reverse current, $T_j = 125\text{ °C}, V_D / V_R = V_{DRM} / V_{RRM}$	I_{DRM} / I_{RRM}	15	mA
Max. average on-state current, $f = 50\text{ Hz}, T_C = 87\text{ °C}$	$I_{T(AV)}$	200	A
RMS on-state current, $T_C = 87\text{ °C}$	I_{TRMS}	314	
Surge non-repetitive current, $T_j = 125\text{ °C}, t_p = 10\text{ ms}, V_R = 0$	I_{TSM}	5	kA
Safety factor	I^2t	$0,125 \cdot 10^6$	A^2s
Critical rate of rise of on-state current, $T_j = 125\text{ °C}, I_T = 400\text{ A}, I_{FG} = 2\text{ A}, t_r = 0,5\ \mu s,$ $V = 0,67V_{DRM}, f = 50\text{ Hz}$	$(di_T/dt)_{crit}$	160	$A/\mu s$
Critical rate of rise of off-state voltage $T_j = 125\text{ °C}, V_D = 0,67V_{DRM}$	$(dv_D/dt)_{crit}$	20-1000	$V/\mu s$
Gate power loss, DC	P_{GM}	4	W
Operation junction temperature range	T_j	-60 + 125	°C
Storage temperature range	T_{stg}	-60 + 50	



T161-200

ELECTRICAL CHARACTERISTICS					
Parameter and conditions	Symbol	Values			Units
		min.	typ.	max.	
Maximum peak on-state voltage, $T_j = 25\text{ °C}$, $I_T = 628\text{ A}$	V_{TM}	-	-	1,60	V
On-state threshold voltage, $T_j = 125\text{ °C}$, $I_T = 300 - 1000\text{ A}$	$V_{T(TO)}$	-	-	1,00	
On-state slope resistance, $T_j = 125\text{ °C}$, $I_T = 300 - 1000\text{ A}$	r_T	-	-	1,05	mΩ
Turn off-time, $T_j = 125\text{ °C}$, $I_T = 200\text{ A}$, $di_T/dt = -5\text{ A}/\mu\text{s}$, $V_R \geq 100\text{ V}$, $V_D = 0,67V_{DRM}$, $dV_D/dt = 50\text{ V}/\mu\text{s}$,	t_q	-	250	-	μs
Recovery charge, $T_j = 125\text{ °C}$, $I_T = 200\text{ A}$, $di_T/dt = -5\text{ A}/\mu\text{s}$, $V_R \geq 100\text{ V}$	Q_{rr}			500	μAs
Reverse recovery maximum current $T_j = 125\text{ °C}$, $I_T = 200\text{ A}$, $di_T/dt = -5\text{ A}/\mu\text{s}$, $V_R \geq 100\text{ V}$	I_{rr}			50	A
Holding current, $T_j = 25\text{ °C}$, $V_D = 12\text{ V}$	I_H	-	-	250	mA
Gate trigger voltage, $V_D = 12\text{ V}$ $T_j = -60\text{ °C}$ $T_j = 25\text{ °C}$ $T_j = 125\text{ °C}$	V_{GT}	-	-	5,0 2,5 2,0	V
Gate trigger current, $V_D = 12\text{ V}$ $T_j = -60\text{ °C}$ $T_j = 25\text{ °C}$ $T_j = 125\text{ °C}$	I_{GT}	-	-	400 200 150	mA
Gate non-trigger voltage, $T_j = 125\text{ °C}$, $V_D = 0,67V_{DRM}$	V_{GD}	0,45			V
THERMAL PARAMETERS					
Thermal resistance junction to case	$R_{th(j-c)}$	-	-	0,13	°C/W
Thermal resistance case to heatsink	$R_{th(j-c)}$	-	-	0,05	
MECHANICAL PARAMETERS					
Weight	w	-	0,24	-	kg
Torque	M_d	20	-	30	Nm
Maximum acceleration (at nominal mounting torque)	a	-	-	50	m/s ²
Cathode-anode distance on insulator surface	D_S	-	20	-	mm



T161-200

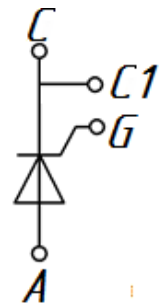
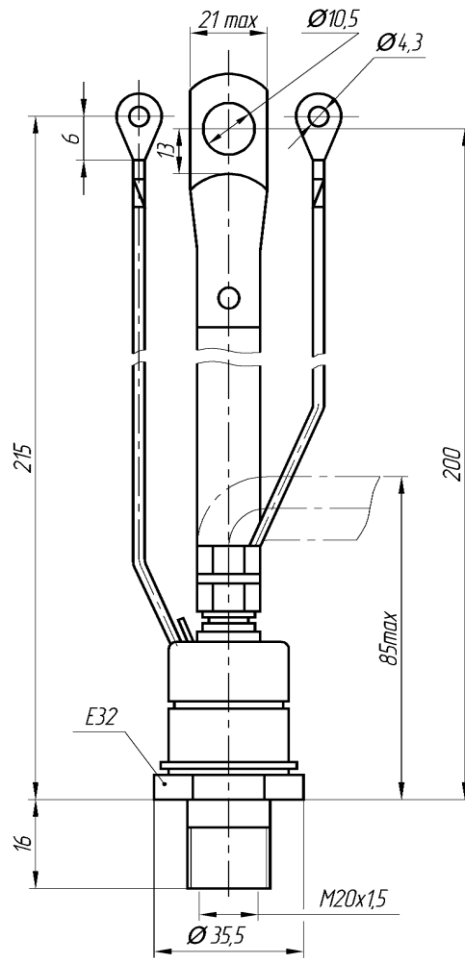

C – Cathode, A – Anode, G – Gate, C1 – Auxiliary cathode

Device Outline Drawing

(dimensions in mm)

Type and length of gate interfaces G and C1 as required by the customer



126, Proletarskaya str.,
430001, Saransk, Republic Mordovia, Russia
Tel: +7(8342) 47-04-30
Tel/Fax: +7 (8342) 47-15-01
E-mail: vpruvs@elvpr.ru
Internet: www.elvpr.ru Internet: www.elvpr.ru