



FAST RECTIFIER DIODE DF351-160X

<ul style="list-style-type: none"> ◆ $V_{RRM} = \underline{600-1400\text{ V}}$ ◆ $I_{F(AV)} = \underline{160\text{ A}}$ ($T_C = 59^\circ\text{C}$) ◆ $I_{FSM} = \underline{3,5\text{ kA}}$ ($t_p = 10\text{ms}$) 		
<ul style="list-style-type: none"> ◆ Small recovered time and charge ◆ Acceptable for series and parallel connections (low dispersion Q_{rr}, V_{FM}, I_{RRM}) 		

MAXIMUM RATED VALUES

Parameter and conditions	Symbol	Values	Units
Repetitive peak reverse voltage, $T_j = -60 \dots +140\text{ }^\circ\text{C}$	V_{RRM}	600-1400	V
Non- repetitive peak reverse voltage, $T_j = -60 \dots +140\text{ }^\circ\text{C}$	V_{RSM}	700-1500	
Repetitive peak reverse current, $T_j = 140\text{ }^\circ\text{C}$, $V_R = V_{RRM}$	I_{RRM}	20	mA
Maximum average forward current, $T_C = 59\text{ }^\circ\text{C}$, $f = 50\text{ Hz}$	$I_{F(AV)}$	160	A
RMS forward current, $T_C = 59\text{ }^\circ\text{C}$, $f = 50\text{ Hz}$	I_{FRMS}	251	
Surge non-repetitive current, $T_j = 140\text{ }^\circ\text{C}$, $V_R = 0$, $t_p = 10\text{ ms}$	I_{FSM}	3,5	kA
Safety factor	I^2t	$61,25 \cdot 10^3$	A^2s
Operation junction temperature range	T_j	-60 ... +140	$^\circ\text{C}$
Storage temperature range	T_{stg}	-60 ... +50	

**DF351-160X**

ELECTRICAL CHARACTERISTICS					
Parameter and conditions	Symbol	Values			Units
		min	typ.	max	
Maximum peak forward voltage, $T_j = 25\text{ °C}$, $I_F = 500\text{ A}$	V_{FM}	-	-	2,45	V
On-state threshold voltage, $T_j = 140\text{ °C}$, $I_F = 250 - 750\text{ A}$	V_{TO}	-	-	1,40	
On-state slope resistance, $T_j = 140\text{ °C}$, $I_F = 250 - 750\text{ A}$	r_T	-	-	1,56	mΩ
Reverse recovery time $T_j = 140\text{ °C}$, $I_F = 160\text{ A}$, $di_F/dt = -50\text{ A}/\mu\text{s}$, $V_R \geq 100\text{ V}$	t_{rr}	-	-	3,2; 4,0	μs
THERMAL PARAMETERS					
Thermal resistance junction to case, DC per diode cathode side cooled	$R_{th(j-c)}$	-	-	0,25	°C/W
Thermal resistance case to heatsink, single side cooled	$R_{th(c-h)}$	-	-	0,08	
MECHANICAL PARAMETERS					
Weight	w	-	0,165	-	kg
Torque	Md	10	-	20	N·m



DF351-160X

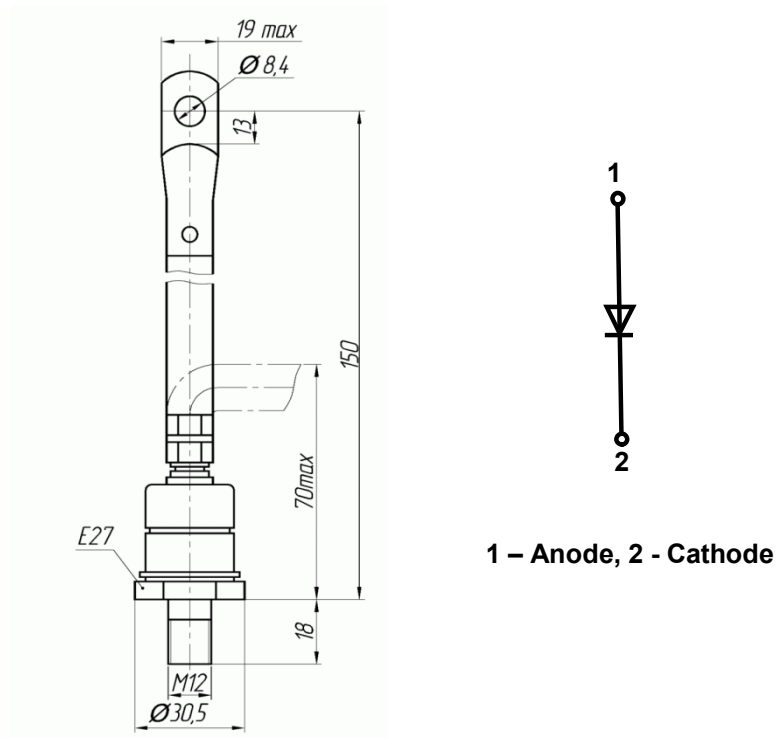

Fig. 1. Device Outline Drawing
(dimensions in mm)



126, Proletarskaya str.,
430001, Saransk, Republic Mordovia, Russia
Tel: +7(8342) 47-04-30
Tel/Fax: +7 (8342) 47-15-01
E-mail: vpruvs@elvpr.ru
Internet: www.elvpr.ru