



## AVALANCHE RECTIFIER DIODE DA153-800

<ul style="list-style-type: none"> <li>◆ <math>V_{RRM} = \mathbf{4400 - 6000\ V}</math></li> <li>◆ <math>I_{F(AV)} = \mathbf{800\ A}</math> (<math>T_C = 90\ ^\circ\text{C}</math>)</li> <li>◆ <math>I_{FSM} = \mathbf{12\ kA}</math> (<math>t_p = 10\text{ms}</math>)</li> </ul>		
<ul style="list-style-type: none"> <li>◆ High reability</li> <li>◆ Guaranteed maximum avalanche power dissipation</li> <li>◆ Press-pack design</li> </ul>		

### MAXIMUM RATED VALUES

Parameter and conditions	Symbol	Values	Units
Repetitive peak reverse voltage, $T_j = -60 \dots +150\ ^\circ\text{C}$	$V_{RRM}$	4400-6000	V
Avalanche breakdown voltage, $T_j = -60 \dots +150\ ^\circ\text{C}$	$V_{BR}$	4900-6600	
Repetitive peak reverse current, $T_j = 150\ ^\circ\text{C}$ , $V_R = V_{RRM}$	$I_{RRM}$	100	mA
Maximum average forward current, $T_C = 90\ ^\circ\text{C}$ , $f = 50\ \text{Hz}$	$I_{F(AV)}$	800	A
RMS forward current, $T_C = 90\ ^\circ\text{C}$ , $f = 50\ \text{Hz}$	$I_{FRMS}$	1256	
Surge non-repetitive current, $T_j = 150\ ^\circ\text{C}$ , $V_R = 0$ , $t_p = 10\ \text{ms}$	$I_{FSM}$	12	kA
Safety factor	$I^2t$	$720 \cdot 10^3$	$\text{A}^2\text{s}$
Operation junction temperature range	$T_j$	-60 ... +150	$^\circ\text{C}$
Storage temperature range	$T_{stg}$	-60 ... +50	

**DA153-800**

<b>ELECTRICAL CHARACTERISTICS</b>					
Parameter and conditions	Symbol	Values			Units
		min	typ.	max	
Maximum peak forward voltage, $T_j = 25\text{ °C}$ , $I_F = 2500\text{ A}$	$V_{FM}$	-	-	2,5	V
On-state threshold voltage, $T_j = 150\text{ °C}$ , $I_F = 1250 - 3800\text{ A}$	$V_{TO}$	-	-	1,31	
On-state slope resistance, $T_j = 150\text{ °C}$ , $I_F = 1250 - 3800\text{ A}$	$r_T$	-	-	0,740	mΩ
Rated reverse power dissipation, $T_j = 150\text{ °C}$ , $t_p = 100\text{ мкс}$	$P_{RSM}$	-	-	16,0	kW
<b>THERMAL PARAMETERS</b>					
Thermal resistance junction to case, DC per diode double side cooled anode side cooled cathode side cooled	$R_{th(j-c)}$	-	-	0,020 0,040 0,040	°C/W
Thermal resistance case to heatsink, double side cooled single side cooled	$R_{th(c-h)}$	-	-	0,005 0,010	
<b>MECHANICAL PARAMETERS</b>					
Weight	w	-	0,55	-	kg
Clamping force	F	22	-	26	kN
Maximum acceleration (at nominal mounting torque)	a	-	-	100	m/s <sup>2</sup>



## DA153-800

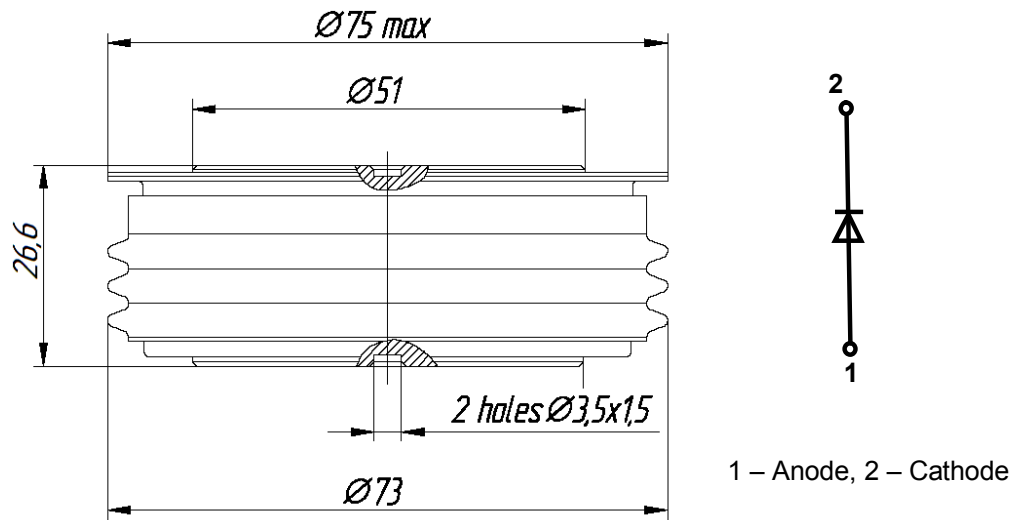

Fig. 1. Device Outline Drawing  
(dimensions in mm)



126, Proletarskaya str.,  
430001, Saransk, Republic Mordovia, Russia  
Tel: +7(8342) 47-04-30  
Tel/Fax: +7 (8342) 47-15-01  
E-mail: vpruvs@elvpr.ru  
Internet: www.elvpr.ru